

# ILDS - an innovative approach for pipeline leak detection

Leaks in liquid and gas pipelines always imply material losses. In some cases, an incident can turn into a critical event, particularly when the transported fluid is dangerous to life or environment

Operators all over the world are continuously increasing their efforts and investments towards integrity programs targeting, primarily, prevention of these undesired events and, consequently, decreasing direct costs (e.g. remediation, penalties, reparations) and indirect costs (e.g. public image, stock devaluation). However, there's always a chance that an accident occurs, no matter how much attention was given to its prevention. For this reason, leak detection systems (LDS) play an important role of integrity programs. LDS are specially designed tools that help operators to identify and react to a spill. They are in-line systems that continuously monitor and alarm deviations of some operational condition which can be associated with a leak. Speed of response, sensitivity, reliability, accuracy and robustness are common performance parameters used to differentiate and assess systems. Last but not least, applicability to a wide range of scenarios is a highly desirable characteristic.

Asel-Tech's new ILDS (Integrated Leak Detection System) has been designed around all the above mentioned characteristics and, most important, featuring two different methodologies to detect leaks: Negative Pressure Wave and Compensated Mass (or Volume) Balance. The concept itself is not new. On the other hand, it is clearly recommended in API RP 1130. The innovative approach is more subtle in the sense that it is hidden inside its hardware and software components.

In order to unveil ILDS innovative nature, one needs to look into the inner layers of its components. This article briefly describes ILDS principles, its architecture, emphasising the synergy between the two methodologies as opposed to other implementations that merely bundled two or more techniques as one package, but running as isolated subsystems. Beyond the additive and complementary nature of a dual methodology (final system inherits characteristics from each individual subsystem), a bidirectional collaborative implementation produces a synergistic improvement in overall performance.

## Detection methodologies

ILDS employs two methods to detect leak events: (1) identification of the negative pressure wave originated by the sudden depressurization (2) identification of an imbalance between inflow and outflow compensated by the line-pack variation over a given time interval. The block diagram of the system is shown on **Fig. 1**

**Negative Pressure Wave** – This subsystem, also known as sonic or acoustic, identifies the characteristic fluid dynamic transient wave that propagates

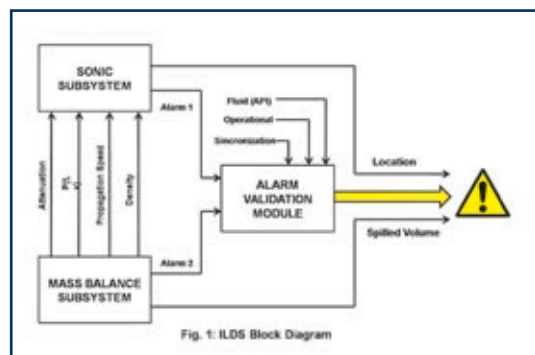

**Marcio Bergh**, graduated in Electric Engineer from FEI in 1984 and post-graduated in Administration and Marketing of Services from FGV/SP. He has worked for 28 years in Automation, Instrumentation, and Processes for the energy, infrastructure, and other industrial segments industries. He was also the Manager for Electric System Integration Projects, Automation and Instrumentation for Paper & Cellulose, Chemical & Petrochemicals and Infrastructure. He is currently the ASEL-TECH business manager for the pipe transport division.



**Jairo A. Prezzi**, an Electronic Engineer with a Master's in Computer Science from UFRGS. Since 1982, he has worked in the industrial automation segment, working in administration and commercial R&D. He was a professor and researcher of the Computer Science Department of UFRGS. Currently, he is the Business Development Manager of Asel-Tech Tecnologia e Automação.



through the fluid, travelling long distances in both directions. Special transducers installed at both ends of the monitored stretch detect and transform pressure into an electrical signal which is read and analyzed by dedicated Field Processing Units (FPU).

The arrival time of the wavefront at each sensor is registered and, since the wave propagation velocity is a known constant for each fluid, the exact position of the leak can be easily calculated. Accuracy of the calculation is assured by GPS which keeps all FPUs clocks synchronized. Presence of back-ground noise and operational events, such as those originated by pump start/stop or valve opening /closing, require several different filtering techniques to be used in order to extract the characteristic leak signature. Effective filtering is the key element of this subsystem. Some examples of filtering are: correlation, band-pass, phase sequence, envelope extractor. The most innovative filtering technique in this subsystem is an artificial neural network (ANN) which reduces significantly the probability of false-alarms.

**Mass Imbalance** – This subsystem infers that a leak exists based on the mass unbalance that results from product release. The detection can roughly be described as the analysis of the behavior of line-pack variation compared to the difference in inlet and outlet flows. The model uses measurements taken at both ends of the monitored stretch, (flow, temperature, pressure and density), pipe and fluid specifications as well as pre-pressure/temperatures measurements at intermediate points. Computational Fluid Dynamics (CFD) algorithms based on real-time transient models (RTTM) run cyclically on the Central Monitoring Station, producing a curve representative of the behavior (signature) of the line-pack variation relative to in-out mass variation. Again, filters based on Artificial Neural Networks (ANN) qualify this signature, or its trend, as being typical of a leak or not. The final decision is taken by the Validation Module which, in its turn, also uses information generated by the Negative Pressure Wave Subsystem to validate the event and declare a LEAK ALARM along with associated informations (position, leak flow rate, duration, etc.).

The validation process and trend analysis employ special algorithms based in artificial neural networks (ANN) which allow the system to distinguish between various operational events and real leaks, reducing dramatically the false-alarm rate, a well known issue for all LDS, specially mass conservation methods.

In order to validate an alarm, the Validation Module performs a cross-check of the corresponding signals received from both subsystems as well as qualitative and quantitative analysis of other variables, e.g. tendency of mass variation. Once recognizes and declared as a LEAK ALARM, the event is displayed to the operator along with relevant information such as the moment it started, its exact location, instantaneous leak rate and total spilled volume.

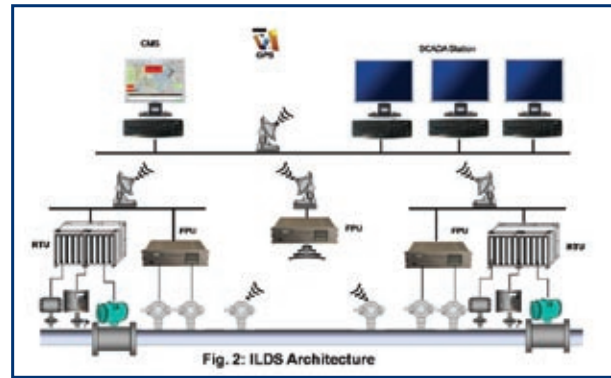

## System architecture

ILDS architecture and its components are shown in Fig. 2. The Negative Pressure Wave Subsystem comprises Acoustic Sensors (FSS), Field Processing Units (FPU) and Central Monitoring Station (CMS). The Mass Balance Subsystem comprises transmitters at both ends of the pipeline (pressure, temperature, flow and density), Remote Terminal Units (RTU) and Central Monitoring Station (CMS).

ILDS architecture is supported by a communication subsystem that can be implemented by different media, like radio, optical fiber, cable, landline, cellular. The protocol is Ethernet. Integration between ILDS and pipeline SCADA is facilitated by an OPC driver embedded in CMS. Moreover, all user interface functions are based on off-the-shelf supervisory package (such as iFix, Intouch, Elipse) according to client preferences. Direct integration of both servers, ILDS and SCADA, allows information about operational events (valve operation, pump start/stop, operational changes, etc.) to be used in the validation module, improving robustness and reliability of the ILDS decision algorithm.

## Conclusion

ILDS dual methodology and innovative implementation allow fast leak detection, precise location and accurate quantification of released product, featuring the following characteristics:

- Two complementary methodologies as recommended in API RP 1130;
- Mass balance algorithms relying on Computational Fluid Dynamics (CFD) models;
- Low false-alarm rate due to pattern recognition based on artificial neural networks techniques;
- Adaptability to different operational conditions and self-learning capability;
- Easy integration with SCADA or DCS using OPC protocol and commercial supervisory packages;
- Fast detection with alarming in the range of 60 seconds or better;
- Sensitivity better than 1% of the nominal flow;
- Location better than 2% of the monitored length;
- Detects progressive and pre-existent leaks;
- Leak detection even with pipeline in shut-in condition. ■